

A1P540E00DZ00X

The right to introduce technical modifications is reserved

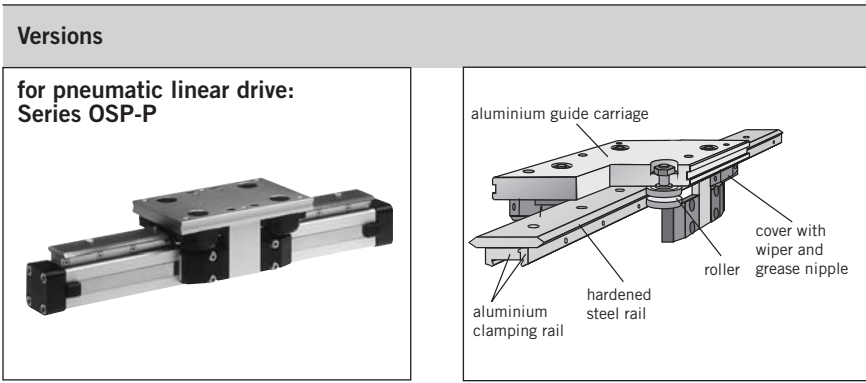

# Roller Guide POWERSLIDE



**Series PS 16 to 50  
for Linear-drive**  
• Series OSP-P

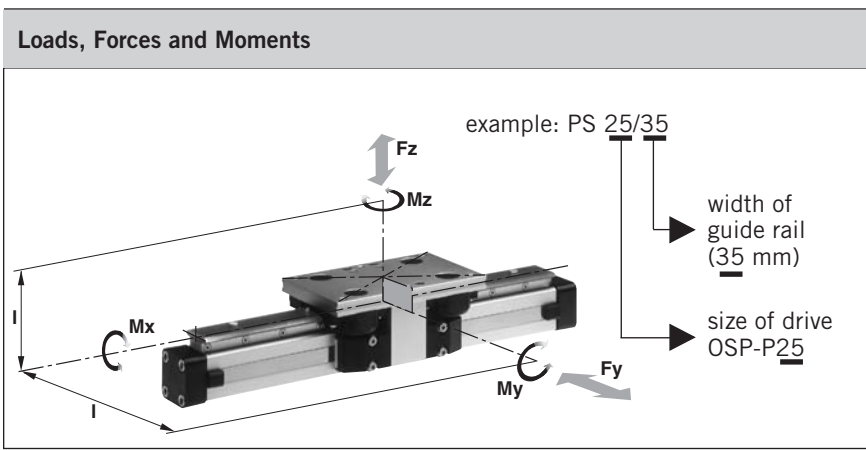

### Technical Data

The Table shows the maximum permissible values for smooth operation, which should not be exceeded even under dynamic conditions. For further information and technical data see data sheets for linear drives OSP-P (1.10.002E)

**\* Please note:**  
In the cushioning diagram, add the mass of the guide carriage to the mass to be cushioned.

### Features:

- Anodised aluminium guide carriage with vee rollers having 2 rows of ball bearings
- Hardened steel guide rail
- Several guide sizes can be used on the same drive
- Corrosion resistance version available on request
- Max. speed  $v = 3 \text{ m/s}$ ,
- Tough roller cover with wiper and grease nipple
- Any length of stroke up to 3500 mm, (longer strokes on request)

Series	For linear drive	Max. moments [Nm]			Max. load [N] Fy, Fz	Mass of linear drive with guide [kg]		Mass * of guide carriage [kg]	Order-No. Powerslide for OSP-P <sup>1)</sup>
		Mx	My	Mz		with 0 mm stroke	increase per 100 mm stroke		
PS 16/25	OSP-P16	14	45	45	1400	0.93	0.24	0.7	20285
PS 25/25	OSP-P25	14	63	63	1400	1.5	0.4	0.7	20015
PS 25/35	OSP-P25	20	70	70	1400	1.7	0.4	0.8	20016
PS 25/44	OSP-P25	65	175	175	3000	2.6	0.5	1.5	20017
PS 32/35	OSP-P32	20	70	70	1400	2.6	0.6	0.8	20286
PS 32/44	OSP-P32	65	175	175	3000	3.4	0.7	1.5	20287
PS 40/44	OSP-P40	65	175	175	3000	4.6	1.1	1.5	20033
PS 40/60	OSP-P40	90	250	250	3000	6	1.3	2.2	20034
PS 50/60	OSP-P50	90	250	250	3000	7.6	1.4	2.3	20288
PS 50/76	OSP-P50	140	350	350	4000	11.5	1.8	4.9	20289

<sup>1)</sup> corrosion resistance version available on request (max. loads and moments are 25% lower)

For linear drives see 1.10.002E  
For mountings see 1.45.005E



## Dimensions

### Series OSP-P

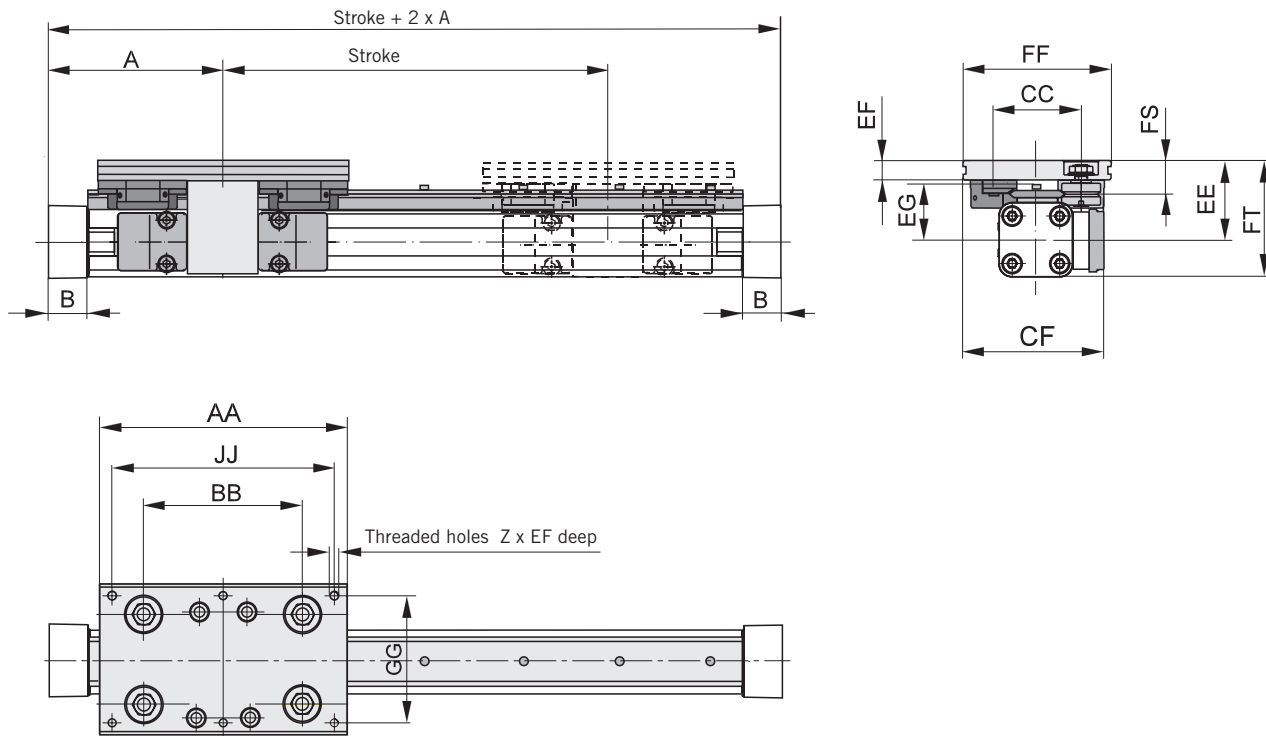

### Dimension Table (mm)

Series	A	B	Z	AA	BB	CC	CF	EE	EF	EG	FF	FS	FT	GG	JJ
PS 16/25	65	14	4xM6	120	65	47	80	49	12	35	80	21	64	64	100
PS 25/25	100	22	6xM6	145	90	47	79.5	53	11	39	80	20	73.5	64	125
PS 25/35	100	22	6xM6	156	100	57	89.5	52.5	12.5	37.5	95	21.5	73	80	140
PS 25/44	100	22	6xM8	190	118	73	100	58	15	39	116	26	78.5	96	164
PS 32/35	125	25.5	6xM6	156	100	57	95.5	58.5	12.5	43.5	95	21.5	84.5	80	140
PS 32/44	125	25.5	6xM8	190	118	73	107	64	15	45	116	26	90	96	164
PS 40/44	150	28	6xM8	190	118	73	112.5	75	15	56	116	26	109.5	96	164
PS 40/60	150	28	6xM8	240	167	89	122.5	74	17	54	135	28.5	108.5	115	216
PS 50/60	175	33	6xM8	240	167	89	130.5	81	17	61	135	28.5	123.5	115	216
PS 50/76	175	33	6xM10	280	178	119	155.5	93	20	64	185	39	135.5	160	250

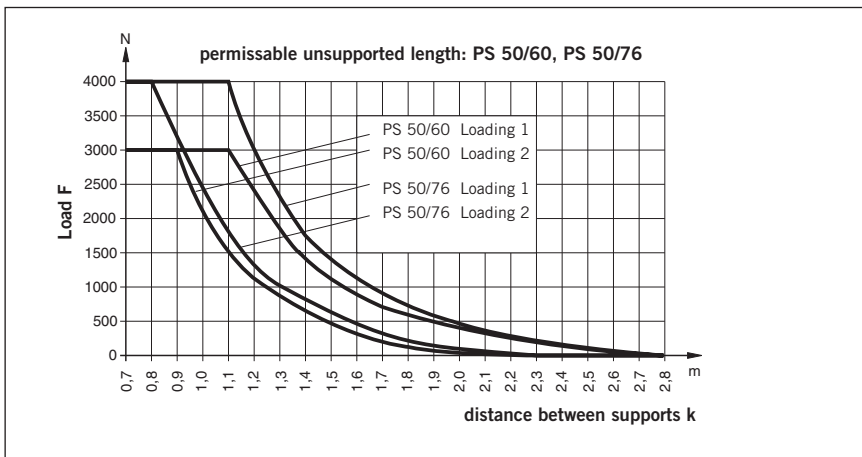
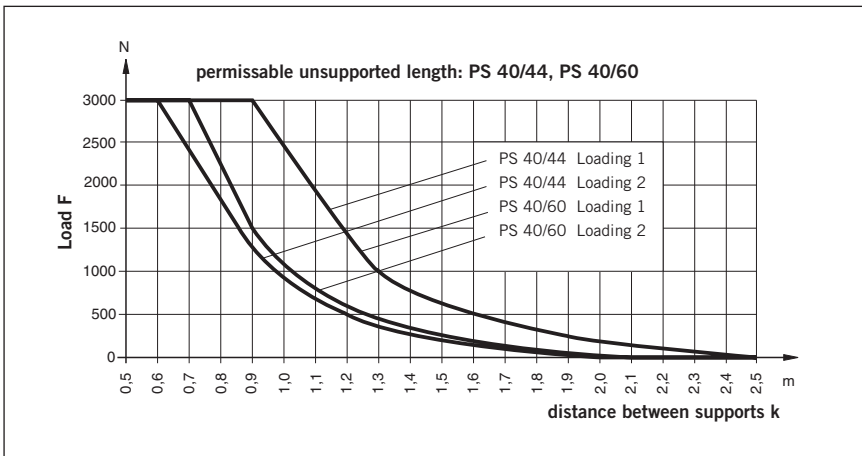
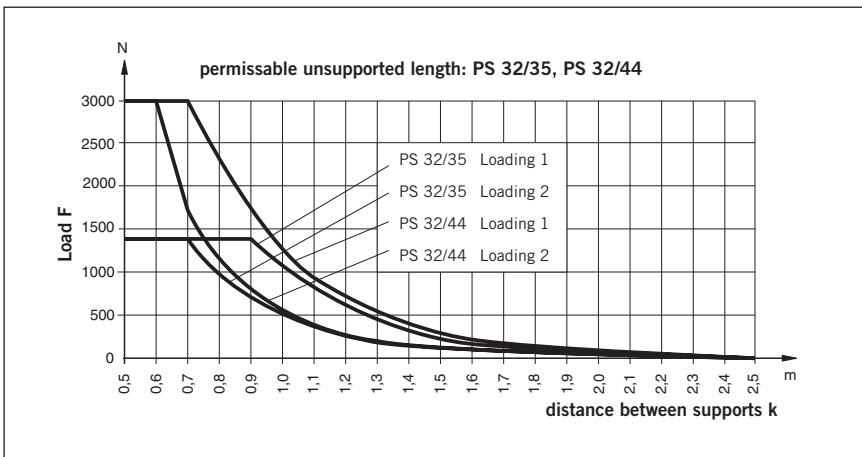
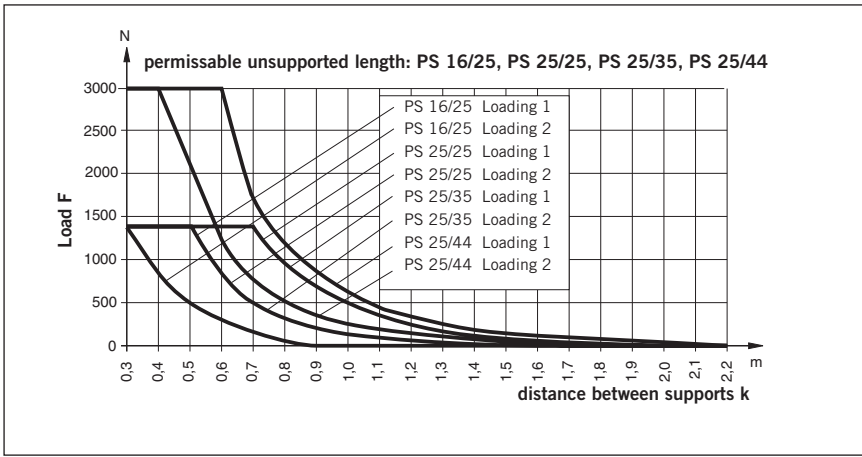

## Mid-Section Support

(for versions, see accessories)

Mid section supports are required from a certain stroke length to prevent excessive deflection and vibration of the linear drive. The diagrams show the maximum permissible unsupported length in relation to loading. A distinction must be drawn between loading 1 and loading 2. Deflection of 0.5 mm max. between supports is permissible.

### Note

For speeds  $v > 0.5$  m/s the distance between supports should not exceed 1m.

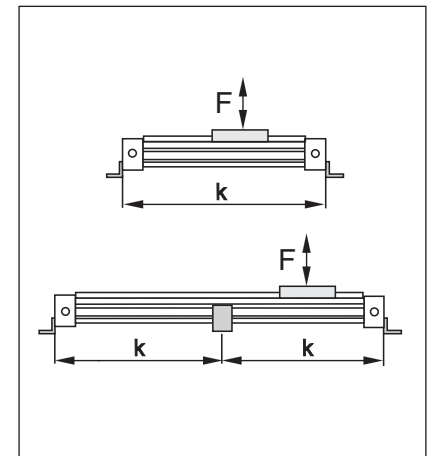
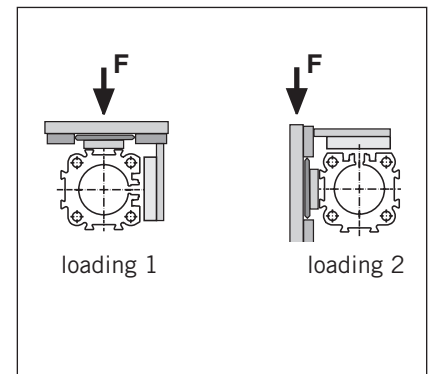

For further mounting elements and options see 1.45.001E.

## Service life

Calculation of service life is achieved in two stages:

- Determination of load factor  $L_F$  from the loads to be carried
- Calculation of service life in km

### 1. Calculation of load factor $L_F$

$$L_F = \frac{M_x}{M_{x_{max}}} + \frac{M_y}{M_{y_{max}}} + \frac{M_z}{M_{z_{max}}} + \frac{F_y}{F_{y_{max}}} + \frac{F_z}{F_{z_{max}}}$$

with combined loads,  $L_F$  should not exceed the value 1.

## Lubrication

For maximum system life, lubrication of the rollers must be maintained at all times.

Only high quality Lithium based greases should be used.

Lubrication intervals are dependant on environmental conditions (temperature, running speed, grease quality etc.) therefore the installation should be regularly inspected.

### 2. Service life calculation

• For PS 16/25, PS 25/25, PS 25/35, and PS 32/35	Service life [km] = $\frac{106}{(L_F + 0,02)^3}$
• For PS 25/44, PS 32/44, PS 40/44, PS 40/60 and PS 50/60:	Service life [km] = $\frac{314}{(L_F + 0,015)^3}$
• For PS 50/76:	Service life [km] = $\frac{680}{(L_F + 0,015)^3}$